

# **Inactivation of *Listeria monocytogenes* on RTE hot dogs treated with volatilized acetic acid**

**Peter Bodnaruk**



**David Lark**



# **Overview**

- **Introduction**
- **Process**
- **Study**
- **Future developments**

**HEALTH RISK: HIGH**  
**Nevada Firm Recalls  
Pork Products For  
Possible *Listeria*  
Contamination**

WASHINGTON, April 17, 2002 -

**Ohio Firm Recalls Franks  
and Hot Dogs For Possible  
*Listeria* Contamination**

WASHINGTON, April 25, 2002 -  
John Morrell & Co., a Cincinnati, Ohio  
firm, is voluntarily recalling approximately  
140,000 pounds of franks and hot dogs that  
are contaminated with *Listeria*  
monocytogenes. The U.S. Department of  
Agriculture and the U.S. Department of  
Health and Human Services are assisting  
the firm in the recall.

**Minnesota Firm Recalls  
Turkey Products  
For Possible *Listeria*  
Contamination**

WASHINGTON, March 15, 2002 - West  
Central Turkeys Inc., a Pelican Rapids,  
Minn., firm, is voluntarily recalling  
approximately 23,000 pounds of fully  
cooked turkey products that may be  
contaminated with *Listeria*  
monocytogenes. The U.S. Department of  
Agriculture and the U.S. Department of  
Health and Human Services are assisting  
the firm in the recall.

**Product For Possible  
*Listeria* Contamination**

WASHINGTON, April  
A.L. Duck Jr. Inc., a Zuni, V  
establishment, is voluntarily  
recalling approximately 190 pounds  
of to-eat souse loaf that may  
be contaminated with *Listeria*  
monocytogenes. The U.S. Department of  
Agriculture and the U.S. Department of  
Health and Human Services are assisting  
the firm in the recall.

**CLASS I RECALL**  
**HEALTH RISK: HIGH**

**New York Firm Recalls  
Franks and Bologna  
For Possible *Listeria*  
Contamination**

WASHINGTON, May 2  
Packing Corp., doing business  
as Ferris, Stahl and  
a New York firm, is voluntarily  
recalling approximately 100,000  
pounds of franks and bologna  
that may be contaminated with  
*Listeria monocytogenes*. The U.S.  
Department of Agriculture and the  
U.S. Department of Health and  
Human Services are assisting the  
firm in the recall.

**New York Firm Recalls  
Imported Cured Ham  
For Possible *Listeria*  
Contamination**

WASHINGTON, June 21, 2002 -  
Boar's Head Provision Co., Inc., a  
Brooklyn, N.Y., establishment, is  
voluntarily recalling approximately  
2,300 pounds of imported cured ham  
that may be contaminated with  
*Listeria monocytogenes*. The U.S.  
Department of Agriculture and the  
U.S. Department of Health and  
Human Services are assisting the  
firm in the recall.

**Indiana Firm Recalls Pizza  
Product For Possible  
*Listeria* Contamination**

WASHINGTON, April 17, 2002 -  
Evansville, Ind.,  
firm, is voluntarily recalling  
approximately 100 pounds of fresh pizza  
that may be contaminated with  
*Listeria monocytogenes*. The U.S.  
Department of Agriculture and the  
U.S. Department of Health and  
Human Services are assisting the  
firm in the recall.

**Country Lite Ham Steaks**

Country Lite Pty Ltd  
Country Lite (reduced fat)  
Use by 21 May 02 and 6  
Use by: approx 180 - 300

Challenge Meats Pty Ltd  
e testing detected  
Listeria may  
women, the very  
people with low

# **Recalls**

***L. monocytogenes***

**RTE meats**

**Sep 2001 to Sep 2002**

- **Approx. 30 recalls**
- **Total of 465,000 pounds**
- **Mean 15,500 pounds**
- **Median 500 pounds**

Source – [Safetyalerts.com](http://Safetyalerts.com)

# **Vaporex Process**

- **Gaseous application of food-grade biocides**
- **Applied prior to packaging**
- **Immediate and some residual effect**
- **Used for foods where final pasteurization step can not be incorporated into process**
- **raw and processed perishable foods**
- **patented process**

# Principle

- **Biocide(s) can be vaporized into a carrier gas by heating them past their boiling point.**

# **Principle**

- **Food grade biocides**
  - **acetic acid, peroxide, peracetic or carbonic acids**

# Principle

- **Biocide partitions into surface moisture of food**
  - **more soluble in surface water than in carrier gas**
  - **biocides rapidly partition from the gas to the surface moisture resulting in a very acidic and/or oxidative surface layer**

# Principle

- Partitioning of the gaseous biocide/s from a carrier gas into the moisture on the surface of a perishable foodstuff is governed by the Second Law of Thermodynamics.

# Principle

- The biocide in gas phase is in a higher energy state than the liquid phase
- Therefore the vaporex process relies on the constant of energy transfer from a higher to a lower state.

# Principle

- Transiently high surface concentrations
- Some diffusion into food
- Most foods equilibrate within 24 h
- Some residual activity
- Any biocide that is volatile can be optimized by the vaporex process.

# **Principle**

- **A rapid rate of partitioning and short contact times (<10sec) minimize the size of application equipment**
- **most existing process lines can be utilized with minimal modification.**

## Influence of pH on % undisociated acid

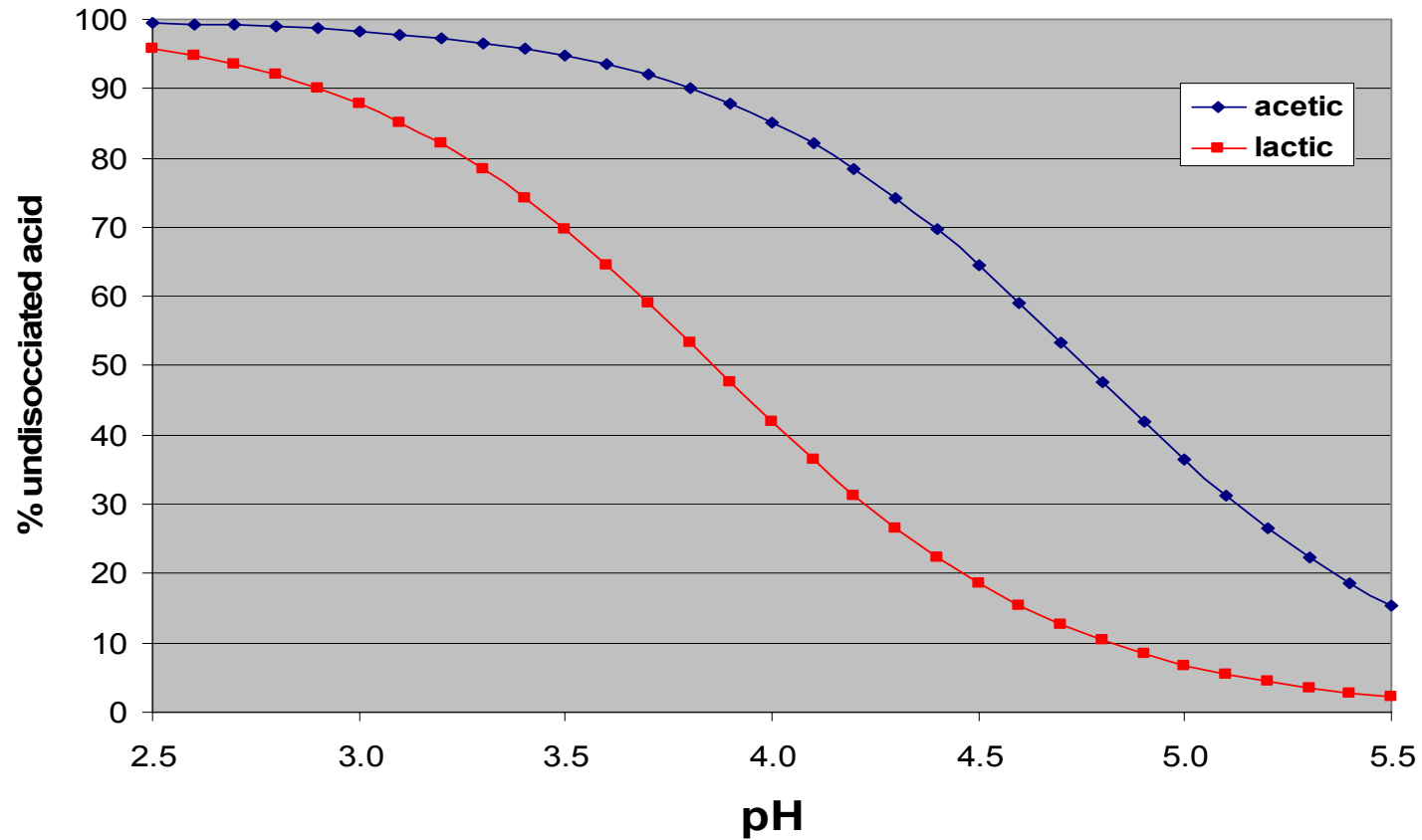

The greater % undisociated the greater bactericidal effect

# ***L. monocytogenes***

- **Cooking inactivates cells**
- **Post process contamination**
- **No terminal anti-listerial treatment**
- **Generally not reheated substantially before consumption**

# Study

- **six-strain mixture of *L. monocytogenes* was inoculated onto the surface of RTE hot dogs.**
  - **Cocktail of strains**
    - **Scott A**
    - **5 meat isolates**
    - **Grown at 8-9°C, 4 d**
    - **Combined at inoculation**
- **inoculated hot dogs were air dried for 20 min.**

# Study

- **Treated with different concentrations of acetic acid vapor (AAV).**
- **Inoculated and treated hot dogs were stored at 4 and 8°C for periods of up to 28 days.**

# Study

- Hot dogs were sampled following the initial treatment with AAV, after 24 h and then every seven days.
- Samples were analyzed for *L. monocytogenes* by enrichment and enumeration.

# Counts

- **General diluent - Fraser broth (without selective supplement)**  
**Added selective supplements ( $1/2$  Fraser), incubated broths at 30°C**
- **Counts – selective and non-selective agar**
- **Broths streaked when black, or at 7 d.**
- **Confirmed presumptive colonies**

HEATER

REGULATOR

GAS FILTER

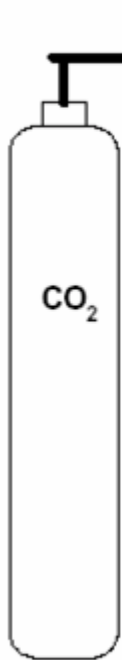

CO<sub>2</sub>

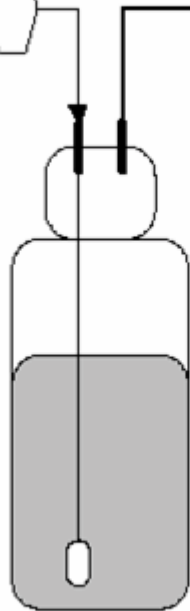
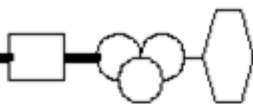

BIOCIDE  
RESERVIOR

SPARGERS

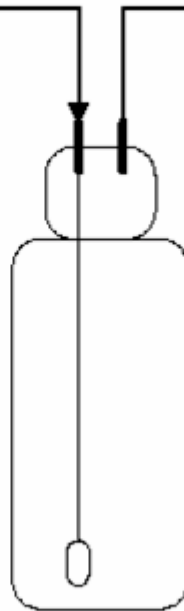

AEROSOL  
TRAP

TO  
SCRUBBER

TO  
PRODUCT

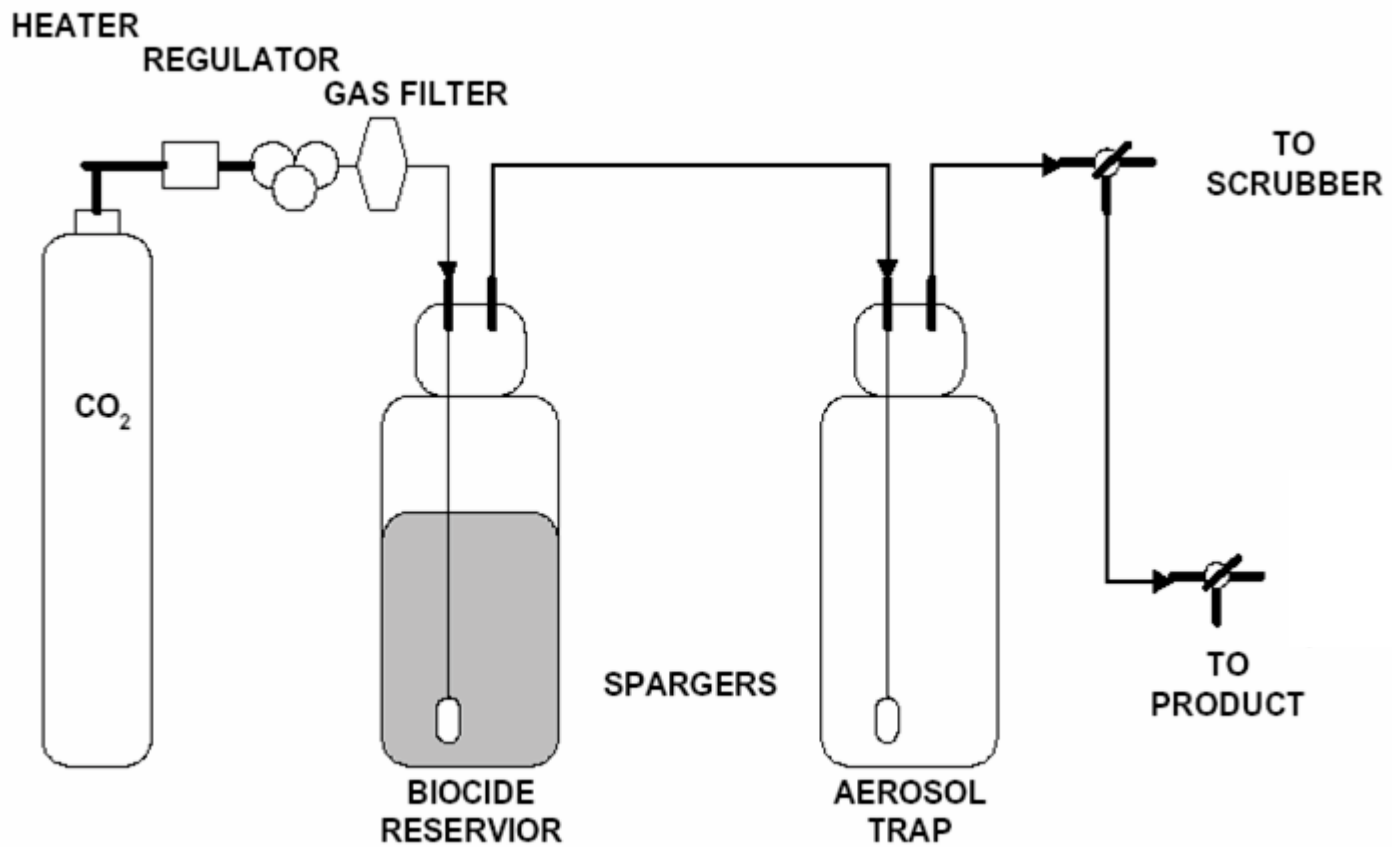

# Results

---

Time after treatment	Surface pH
30 s	2.9 - 3.5
1 h	4.3 - 4.6
22 h	5.0 - 5.4
7 d	5.1 - 5.5
7 d homogenate	5.7

---

# Results

Test conditions used for treating hot dogs

Treatment	Hot dog temp. at treatment (°C)	CO <sub>2</sub> /AAV Temp (°C)	Mean biocide conc. (mg/cm <sup>2</sup> hot dog)	Incubation time (days)
1	2	36	2.53	14
2	22	36	1.37	28
3	22	36	1.48	28

# Results

Fate of *L. monocytogenes* on treated hot dogs over 28 day storage at 4°C (log CFU/g)

Treat	Day 0	Day 1	Day 7	Day 14	Day 21	Day 28
Cont	4.2	3.9	3.8	4.0	3.8	6.1
1	4.2	3.0	1.8	-0.2	NT	NT
2	4.0	1.9	1.8	2.3	2.0	1.3
3	4.0	2.8	2.2	2.1	2.3	1.3

NT - not tested

# Results

Fate of *L. monocytogenes* on treated hot dogs over 28 day storage at 8°C (log CFU/g)

Treat	Day 0	Day 1	Day 7	Day 14	Day 21	Day 28
Cont	4.2	3.9	4.3	8.3	NT	NT
1	4.2	2.0	1.7	1.6	NT	NT
2	4.0	1.9	2.4	1.8	1.6	1.3
3	4.0	2.3	2.2	2.2	2.4	1.3

NT - not tested

# Study

- **Studies showed that surface treatment of inoculated hot dogs with AAV resulted in a 2 D reduction after 24 h storage.**
- **An additional 3 D reduction was noted in some treatments during extended storage indicating the treatment had a residual effect.**

# **Study**

- **The data indicate that this process has potential to offer a validated pathogen reduction step**
- **part of a risk management system.**

# **Application**

- **treatment point after last human contact**
- **use of gas curtain type applicator on collator**

# **Application**

- **Little modification to existing process lines required**
- **High accuracy and precision dosing**
- **Short contact time (< 10s)**

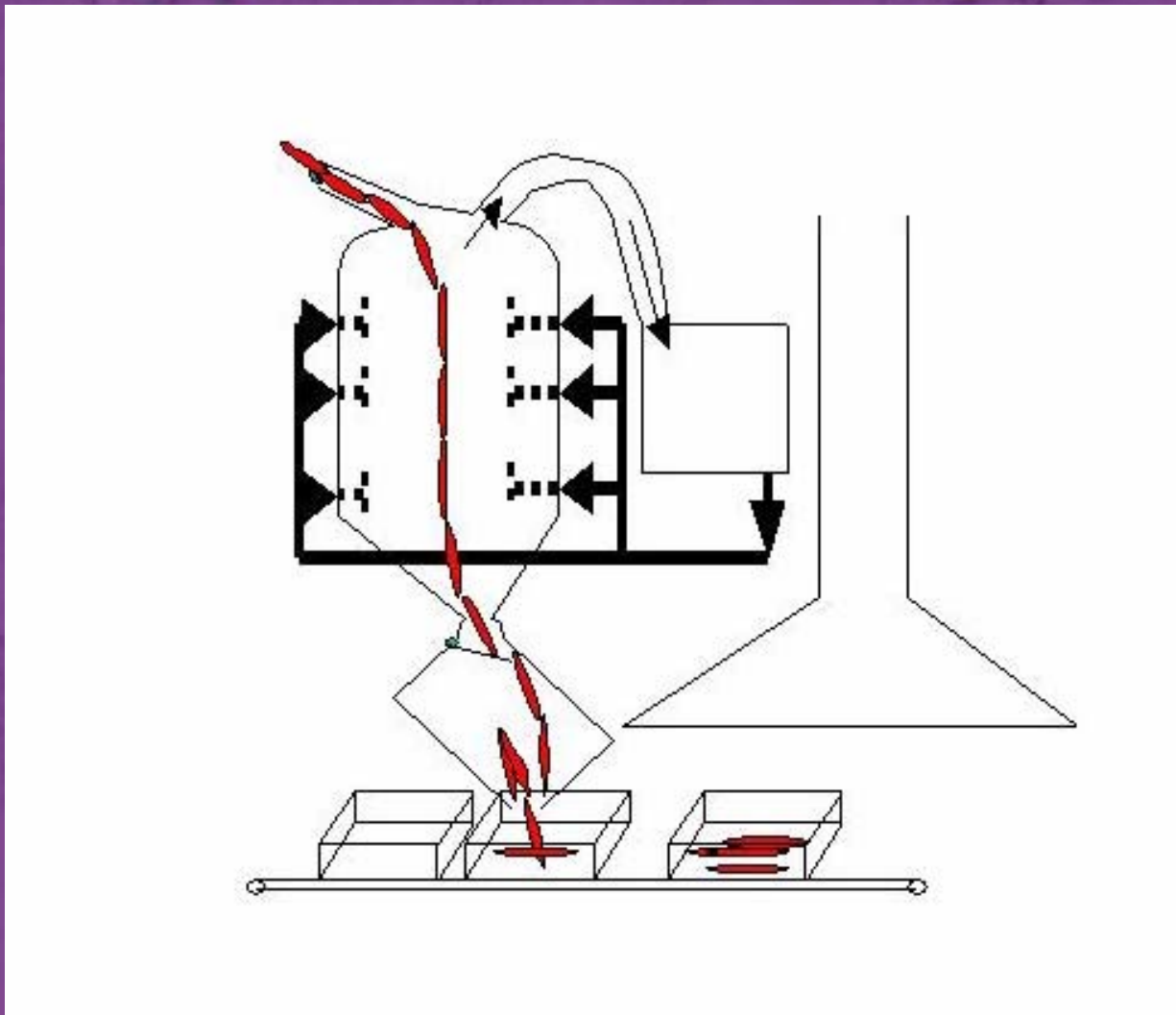

# **Control points**

- **Optimal surface concentrations**
- **Removal of excessive surface moisture**
  - **Biocide dilution effect - decreased efficacy**
- **Retain traditional preservatives**

# **Control points**

- **Physical “shielding” must be eliminated**
  - **surfaces in contact (sliced meats)**
  - **excessive moisture & organic films**

# **Effectiveness..**

- Specialized films not required
- A blend of the different biocides could be used to maximize effectiveness and reduce flavor effects

# **Flavor**

- **Little or no effect on flavor**
  - **No FSA data yet**
- **Can be minimized by addition of alkali e.g. calcium hydroxide to food emulsion**

# **Cost**

- **Consumable cost typically 0.5 to 5c/lb of treated product**
- **Relative to surface area to mass ratio**

# **Future**

- **Balancing of flavor profiles**
- **Point of application**
  - **sliced meats**
- **Engineering of dedicated equipment**
- **Investigate treatment of carcasses**

# Other potential applications

- Cheese
- Bakery Products
- “Fresh” Pasta
- Seafood

# Conclusion

- Selection of critical control point for point of application in the process line
- Post process protection depends on
  - total preservation system
  - buffering effect of food
  - quantity and type/s of biocide used
- Acetic acid can cause flavor detriment if not optimized.

# **Conclusions**

- **An initial 2 log reduction can be obtained within 24h**
- **A residual effect further increased the anti-listerial effect**
- **More studies required to refine dosage and other conditions**

## **Brisbane**

**Public Health Microbiology  
Meat microbiology  
Risk Assessment/Management**

## **Sydney**

**Minimal Processing & Preservation  
Mycology & Mycotoxins  
Analytical Chemistry**

## **Melbourne**

**Minimal Processing & Preservation  
Dairy Microbiology  
Molecular methods**



